

The RF Sub-Micron MOSFET Line

RF Power Field Effect Transistors

N-Channel Enhancement-Mode Lateral MOSFETs

MRF284R1
MRF284LSR1

Designed for PCN and PCS base station applications with frequencies from 1000 to 2600 MHz. Suitable for FM, TDMA, CDMA, and multicarrier amplifier applications. To be used in Class A and Class AB for PCN-PCS/cellular radio and wireless local loop.

2000 MHz, 30 W, 26 V
LATERAL N-CHANNEL
BROADBAND
RF POWER MOSFETs

- Specified Two-Tone Performance @ 2000 MHz, 26 Volts
Output Power = 30 Watts PEP
Power Gain = 9 dB
Efficiency = 30%
Intermodulation Distortion = -29 dBc
- Typical Single-Tone Performance at 2000 MHz, 26 Volts
Output Power = 30 Watts CW
Power Gain = 9.5 dB
Efficiency = 45%
- Capable of Handling 10:1 VSWR, @ 26 Vdc, 2000 MHz, 30 Watts CW Output Power
- Excellent Thermal Stability
- Characterized with Series Equivalent Large-Signal Impedance Parameters
- In Tape and Reel. R1 Suffix = 500 Units per 32 mm, 13 inch Reel.
- Available with Low Gold Plating Thickness on Leads. L Suffix Indicates 40μ" Nominal.

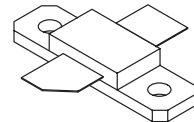

CASE 360B-05, STYLE 1
NI-360
MRF284R1

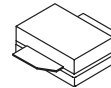

CASE 360C-05, STYLE 1
NI-360S
MRF284LSR1

MAXIMUM RATINGS

Rating	Symbol	Value	Unit
Drain-Source Voltage	V_{DSS}	65	Vdc
Gate-Source Voltage	V_{GS}	±20	Vdc
Total Device Dissipation @ $T_C = 25^\circ\text{C}$ Derate above 25°C	P_D	87.5 0.5	Watts W/°C
Storage Temperature Range	T_{stg}	-65 to +150	°C
Operating Junction Temperature	T_J	200	°C

THERMAL CHARACTERISTICS

Characteristic	Symbol	Max	Unit
Thermal Resistance, Junction to Case	$R_{\theta JC}$	2.0	°C/W

ELECTRICAL CHARACTERISTICS ($T_C = 25^\circ\text{C}$ unless otherwise noted)

Characteristic	Symbol	Min	Typ	Max	Unit
----------------	--------	-----	-----	-----	------

OFF CHARACTERISTICS

Drain-Source Breakdown Voltage ($V_{GS} = 0, I_D = 10 \mu\text{A}$)	$V_{(BR)DSS}$	65	—	—	Vdc
Zero Gate Voltage Drain Current ($V_{DS} = 20 \text{ Vdc}, V_{GS} = 0$)	I_{DSS}	—	—	1.0	μA _{dc}
Gate-Source Leakage Current ($V_{GS} = 20 \text{ Vdc}, V_{DS} = 0$)	I_{GSS}	—	—	10	μA _{dc}

NOTE - **CAUTION** - MOS devices are susceptible to damage from electrostatic charge. Reasonable precautions in handling and packaging MOS devices should be observed.

ELECTRICAL CHARACTERISTICS — continued ($T_C = 25^\circ\text{C}$ unless otherwise noted)

Characteristic	Symbol	Min	Typ	Max	Unit
ON CHARACTERISTICS					
Gate Threshold Voltage ($V_{DS} = 10\text{ Vdc}$, $I_D = 150\ \mu\text{Adc}$)	$V_{GS(th)}$	2.0	3.0	4.0	Vdc
Gate Quiescent Voltage ($V_{DS} = 26\text{ Vdc}$, $I_D = 200\ \text{mAdc}$)	$V_{GS(q)}$	3.0	4.0	5.0	Vdc
Drain–Source On–Voltage ($V_{GS} = 10\text{ Vdc}$, $I_D = 1.0\ \text{Adc}$)	$V_{DS(on)}$	—	0.3	0.6	Vdc
Forward Transconductance ($V_{DS} = 10\text{ Vdc}$, $I_D = 1.0\ \text{Adc}$)	g_{fs}	—	1.5	—	S
DYNAMIC CHARACTERISTICS					
Input Capacitance ($V_{DS} = 26\text{ Vdc}$, $V_{GS} = 0$, $f = 1.0\ \text{MHz}$)	C_{iss}	—	43	—	pF
Output Capacitance ($V_{DS} = 26\text{ Vdc}$, $V_{GS} = 0$, $f = 1.0\ \text{MHz}$)	C_{oss}	—	23	—	pF
Reverse Transfer Capacitance ($V_{DS} = 26\text{ Vdc}$, $V_{GS} = 0$, $f = 1.0\ \text{MHz}$)	C_{rss}	—	1.4	—	pF
FUNCTIONAL TESTS (in Motorola Test Fixture, 50 ohm system)					
Common–Source Power Gain ($V_{DD} = 26\text{ Vdc}$, $P_{out} = 30\ \text{W}$, $I_{DQ} = 200\ \text{mA}$, $f_1 = 2000.0\ \text{MHz}$, $f_2 = 2000.1\ \text{MHz}$)	G_{ps}	9	10.5	—	dB
Drain Efficiency ($V_{DD} = 26\text{ Vdc}$, $P_{out} = 30\ \text{W}$, $I_{DQ} = 200\ \text{mA}$, $f_1 = 2000.0\ \text{MHz}$, $f_2 = 2000.1\ \text{MHz}$)	η	30	35	—	%
Intermodulation Distortion ($V_{DD} = 26\text{ Vdc}$, $P_{out} = 30\ \text{W}$, $I_{DQ} = 200\ \text{mA}$, $f_1 = 2000.0\ \text{MHz}$, $f_2 = 2000.1\ \text{MHz}$)	IMD	—	–32	–29	dBc
Input Return Loss ($V_{DD} = 26\text{ Vdc}$, $P_{out} = 30\ \text{W}$, $I_{DQ} = 200\ \text{mA}$, $f_1 = 2000.0\ \text{MHz}$, $f_2 = 2000.1\ \text{MHz}$)	IRL	—	–15	–9	dB
Common–Source Amplifier Power Gain ($V_{DD} = 26\text{ Vdc}$, $P_{out} = 30\ \text{W PEP}$, $I_{DQ} = 200\ \text{mA}$, $f_1 = 1930.0\ \text{MHz}$, $f_2 = 1930.1\ \text{MHz}$)	G_{ps}	9	10.4	—	dB
Drain Efficiency ($V_{DD} = 26\text{ Vdc}$, $P_{out} = 30\ \text{W PEP}$, $I_{DQ} = 200\ \text{mA}$, $f_1 = 1930.0\ \text{MHz}$, $f_2 = 1930.1\ \text{MHz}$)	η	—	35	—	%
Intermodulation Distortion ($V_{DD} = 26\text{ Vdc}$, $P_{out} = 30\ \text{W PEP}$, $I_{DQ} = 200\ \text{mA}$, $f_1 = 1930.0\ \text{MHz}$, $f_2 = 1930.1\ \text{MHz}$)	IMD	—	–34	—	dBc
Input Return Loss ($V_{DD} = 26\text{ Vdc}$, $P_{out} = 30\ \text{W PEP}$, $I_{DQ} = 200\ \text{mA}$, $f_1 = 1930.0\ \text{MHz}$, $f_2 = 1930.1\ \text{MHz}$)	IRL	—	–15	–9	dB
Common–Source Amplifier Power Gain ($V_{DD} = 26\text{ Vdc}$, $P_{out} = 30\ \text{W CW}$, $I_{DQ} = 200\ \text{mA}$, $f_1 = 2000.0\ \text{MHz}$)	G_{ps}	8.5	9.5	—	dB
Drain Efficiency ($V_{DD} = 26\text{ Vdc}$, $P_{out} = 30\ \text{W CW}$, $I_{DQ} = 200\ \text{mA}$, $f_1 = 2000.0\ \text{MHz}$)	η	35	45	—	%
Output Mismatch Stress ($V_{DD} = 26\text{ Vdc}$, $P_{out} = 30\ \text{W CW}$, $I_{DQ} = 200\ \text{mA}$, $f_1 = 2000.0\ \text{MHz}$, $V_{SWR} = 10:1$, at All Phase Angles)	Ψ	No Degradation In Output Power			

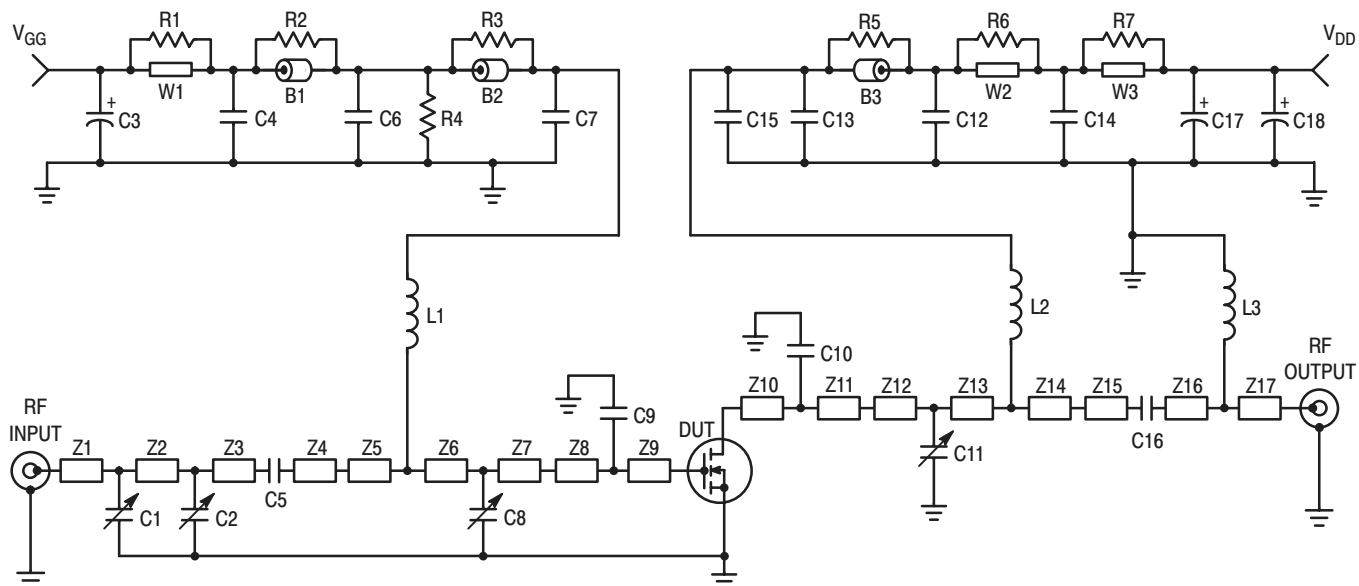

- | | | | |
|-----|----------------------------|-----|--|
| Z1 | 0.530" x 0.080" Microstrip | Z11 | 0.155" x 0.515" Microstrip |
| Z2 | 0.255" x 0.080" Microstrip | Z12 | 0.120" x 0.325" Microstrip |
| Z3 | 0.600" x 0.080" Microstrip | Z13 | 0.150" x 0.325" Microstrip |
| Z4 | 0.525" x 0.080" Microstrip | Z14 | 0.010" x 0.325" Microstrip |
| Z5 | 0.015" x 0.325" Microstrip | Z15 | 0.505" x 0.080" Microstrip |
| Z6 | 0.085" x 0.325" Microstrip | Z16 | 0.865" x 0.080" Microstrip |
| Z7 | 0.165" x 0.325" Microstrip | Z17 | 0.525" x 0.080" Microstrip |
| Z8 | 0.110" x 0.515" Microstrip | PCB | Arlon GX0300–55–22, 0.030",
ε _r = 2.55 |
| Z9 | 0.095" x 0.515" Microstrip | | |
| Z10 | 0.050" x 0.515" Microstrip | | |

Figure 1. 1.93–2.0 GHz Broadband Test Circuit Schematic

Table 1. 1.93 – 2.0 GHz Broadband Test Circuit Component Designations and Values

Designators	Description
B1 – B3	Ferrite Beads, Round, Ferroxcube #56–590–65–3B
C1, C2, C8	0.8–8.0 pF Gigatrim Variable Capacitors, Johanson #27291SL
C3, C17	22 μF, 35 V Tantalum Surface Mount Chip Capacitors, Kemet #T491X226K035AS4394
C4, C14	0.1 μF Chip Capacitors, Kemet #CDR33BX104AKWS
C5	220 pF Chip Capacitor, B Case, ATC #100B221KP500X
C6, C12	1000 pF Chip Capacitors, B Case, ATC #100B102JCA50X
C7, C13	5.1 pF Chip Capacitors, B Case, ATC #100B5R1CCA500X
C9	1.2 pF Chip Capacitor, B Case, ATC #100B1R2CCA500X
C10	2.7 pF Chip Capacitor, B Case, ATC #100B2R7CCA500X
C11	0.6–4.5 pF Gigatrim Variable Capacitors, Johanson #27271SL
C15, C16	200 pF Chip Capacitors, B Case, ATC #100B201KP500X
C18	10 μF, 35 V Tantalum Surface Mount Chip Capacitor, Kemet #T495X106K035AS4394
L1, L2	4 Turns, #24 AWG, 0.120" OD, 0.140" Long, (12.5 nH), Coilcraft #A04T–5
L3	2 Turns, #24 AWG, 0.120" OD, 0.140" Long, (5.0 nH), Coilcraft #A02T–5
R1, R2, R3, R5, R6, R7	12 Ω, 1/4 W Chip Resistors, 0.08" x 0.13", Garrett Instruments #RM73B2B120JT
R4	560 kΩ, 1/4 W Chip Resistor, 0.08" x 0.13"
W1, W2, W3	Solid Copper Buss Wire, 16 AWG
WS1, WS2	Beryllium Copper Wear Blocks 0.005" x 0.250" x 0.250"

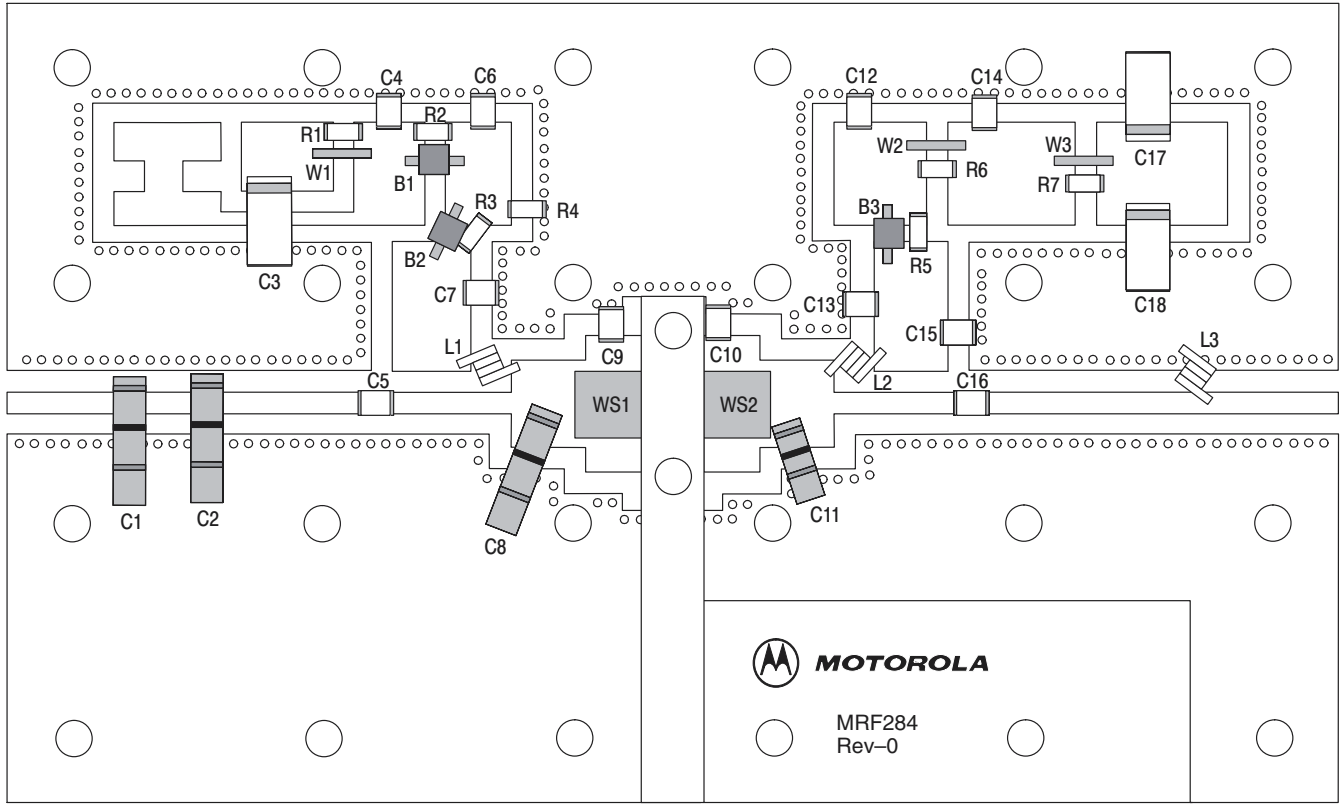
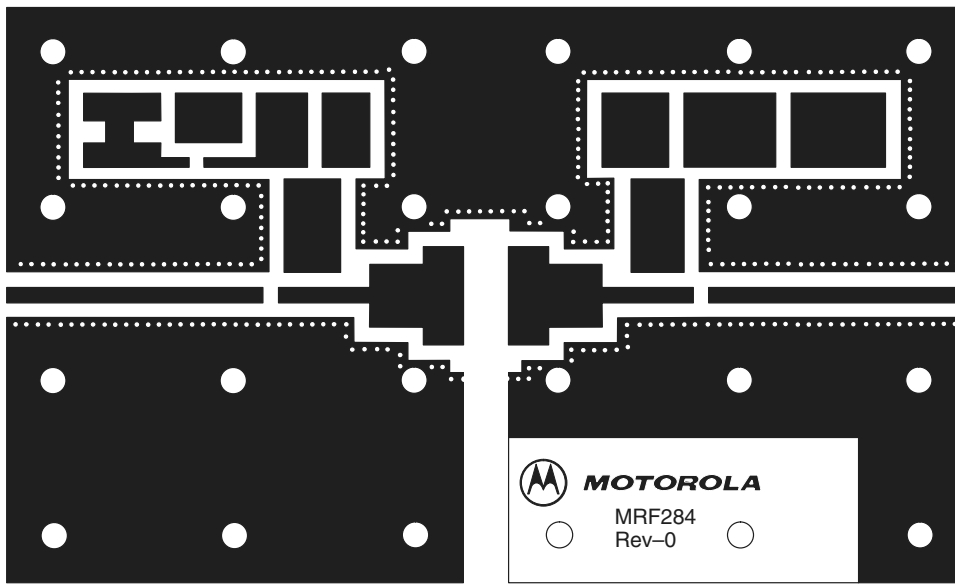
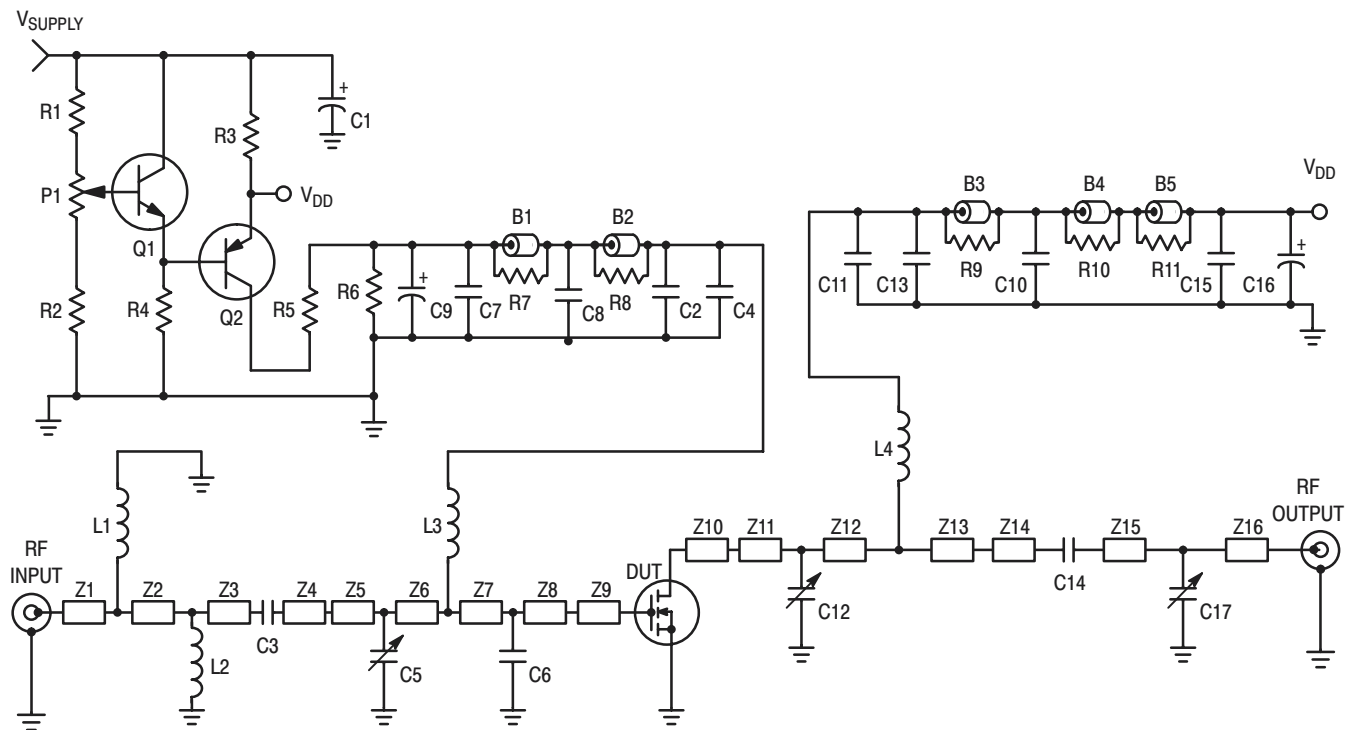

Figure 2. 1.93–2.0 GHz Broadband Test Circuit Component Layout



(Scale 1:1)

Figure 3. MRF284 Test Circuit Photomaster
(Reduced 18% in printed data book, DL110/D)



Z1 0.363" x 0.080" Microstrip
 Z2 0.080" x 0.080" Microstrip
 Z3 0.916" x 0.080" Microstrip
 Z4 0.517" x 0.080" Microstrip
 Z5 0.050" x 0.325" Microstrip
 Z6 0.050" x 0.325" Microstrip
 Z7 0.071" x 0.325" Microstrip
 Z8 0.125" x 0.325" Microstrip
 Z9 0.210" x 0.515" Microstrip

Z10 0.210" x 0.515" Microstrip
 Z11 0.235" x 0.325" Microstrip
 Z12 0.02" x 0.325" Microstrip
 Z13 0.02" x 0.325" Microstrip
 Z14 0.510" x 0.080" Microstrip
 Z15 0.990" x 0.080" Microstrip
 Z16 0.390" x 0.080" Microstrip
 PCB Arlon GX0300-55-22, 0.030",
 $\epsilon_r = 2.55$

Figure 4. 2.0 GHz Class A Test Circuit Schematic

Table 2. 2.0 GHz Class A Test Circuit Component Designations and Values

Designators	Description
B1 – B5	Ferrite Beads, Round, Ferroxcube # 56–590–65–3B
C1, C9, C16	100 μ F, 50 V Electrolytic Capacitors, Mallory #SME50VB101M12X25L
C2, C13	51 pF Chip Capacitors, B Case, ATC #100B510JCA500x
C3, C14	10 pF Chip Capacitors, B Case, ATC #100B100JCA500X
C4, C11	12 pF Chip Capacitors, B Case, ATC #100B120JCA500X
C5	0.8 – 8.0 pF Variable Capacitor, Johansen Gigatrim #27291SL
C6	4.7 pF Chip Capacitor, B Case, ATC #100B4R7CCA500X
C7, C15	91 pF Chip Capacitors, B Case, ATC #100B910KP500X
C8	1000 pF Chip Capacitor, B Case, ATC #100B102JCA50X
C10	0.1 μ F Chip Capacitor, Kemet #CDR33BX104AKWS
C12, C17	0.6 – 4.5 pF Variable Capacitors, Johansen Gigatrim #27271SL
L1	4 Turns, #27 AWG, 0.087" OD, 0.050" ID, 0.069" Long, 10 nH
L2	5 Turns, #24 AWG, 0.083" OD, 0.040" ID, 0.128" Long, 12.5 nH
L3, L4	9 Turns, #26 AWG, 0.080" OD, 0.046" ID, 0.170" Long, 30.8 nH
P1	1000 Ω Potentiometer, 1/2 W, 10 Turns, Bourns
Q1	Transistor, NPN, Motorola P/N: MJD31, Case 369A–10
Q2	Transistor, PNP, Motorola P/N: MJD32, Case 369A–10
R1	360 Ω , Fixed Film Chip Resistor, 0.08" x 0.13", Garrett Instruments #RM73B2B361JT
R2	2 x 12 k Ω , Fixed Film Chip Resistor, 0.08" x 0.13", Garrett Instruments #RM73B2B122JT
R3	1 Ω , Wirewound, 5 W, 3% Resistor, Dale # RE60G1R00
R4	4 x 6.8 k Ω , Fixed Film Chip Resistor, 0.08" x 0.13", Garrett Instruments #RM73B2B682JT
R5	2 x 1500 Ω , Fixed Film Chip Resistor, 0.08" x 0.13", Garrett Instruments #RM73B2B152JT
R6	270 Ω , Fixed Film Chip Resistor, 0.08" x 0.13", Garrett Instruments #RM73B2B271JT
R7 – R11	12 Ω , Fixed Film Chip Resistors, 0.08" x 0.13", Garrett Instruments #RM73B2B120JT

TYPICAL CHARACTERISTICS

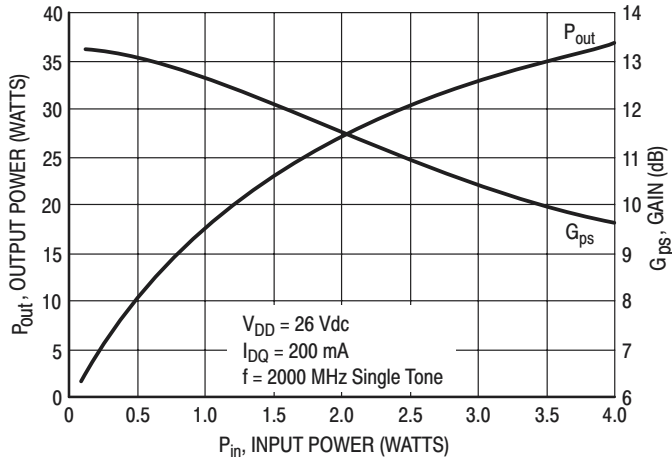

Figure 5. Output Power & Power Gain versus Input Power

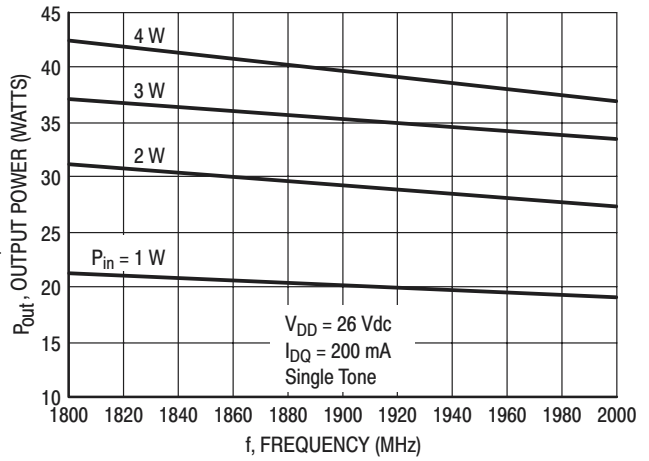

Figure 6. Output Power versus Frequency

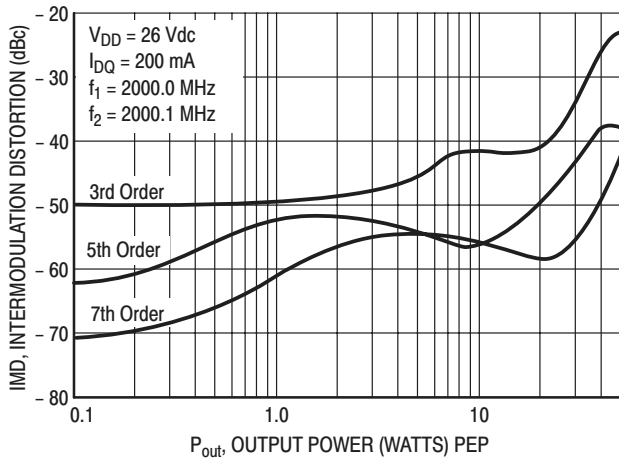

Figure 7. Intermodulation Distortion Products versus Output Power

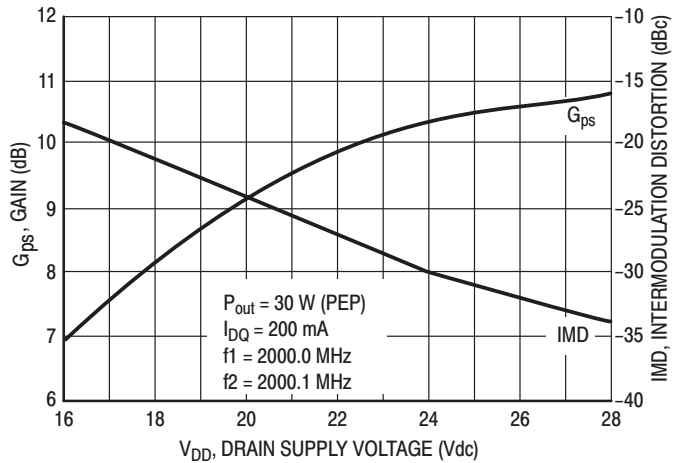

Figure 8. Power Gain and Intermodulation Distortion versus Supply Voltage

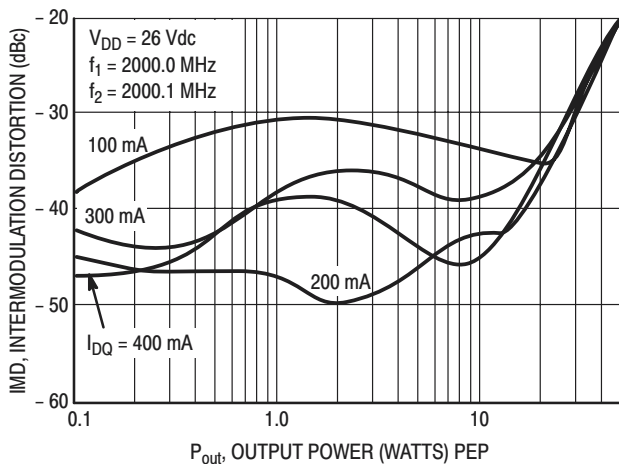

Figure 9. Intermodulation Distortion versus Output Power

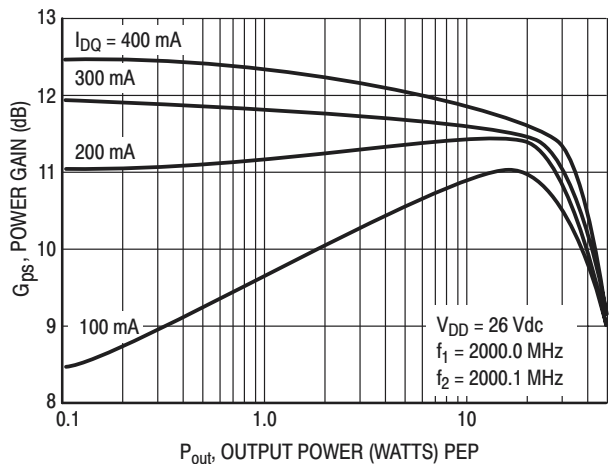

Figure 10. Power Gain versus Output Power

TYPICAL CHARACTERISTICS

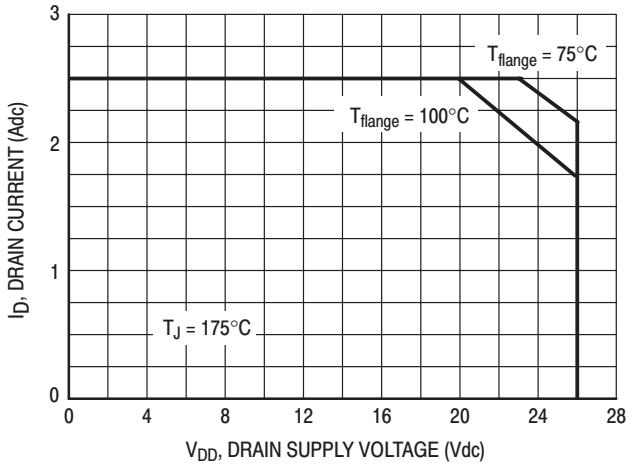

Figure 11. DC Safe Operating Area

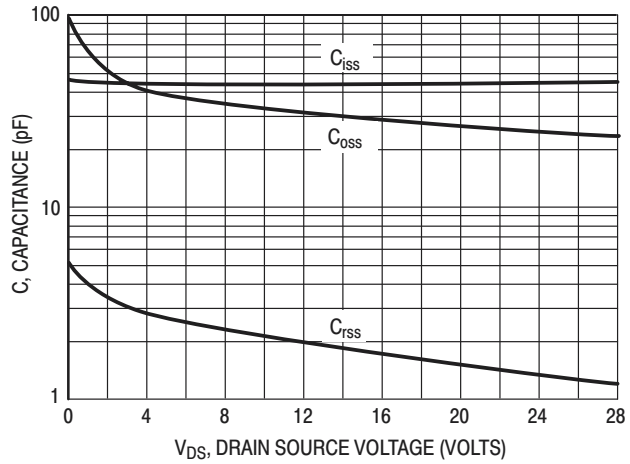

Figure 12. Capacitance versus Drain Source Voltage

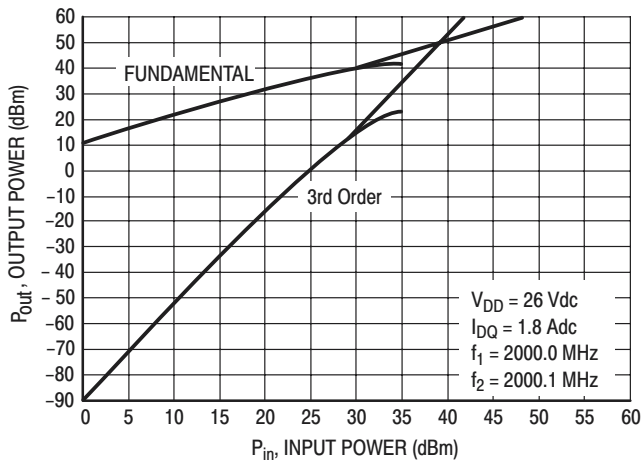
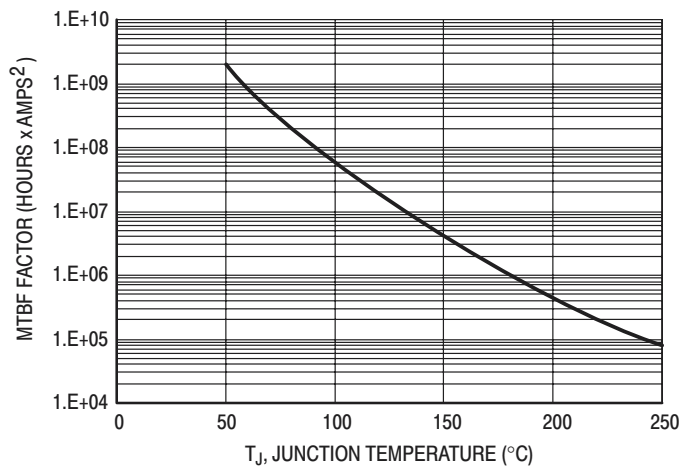

Figure 13. Class A Third Order Intercept Point

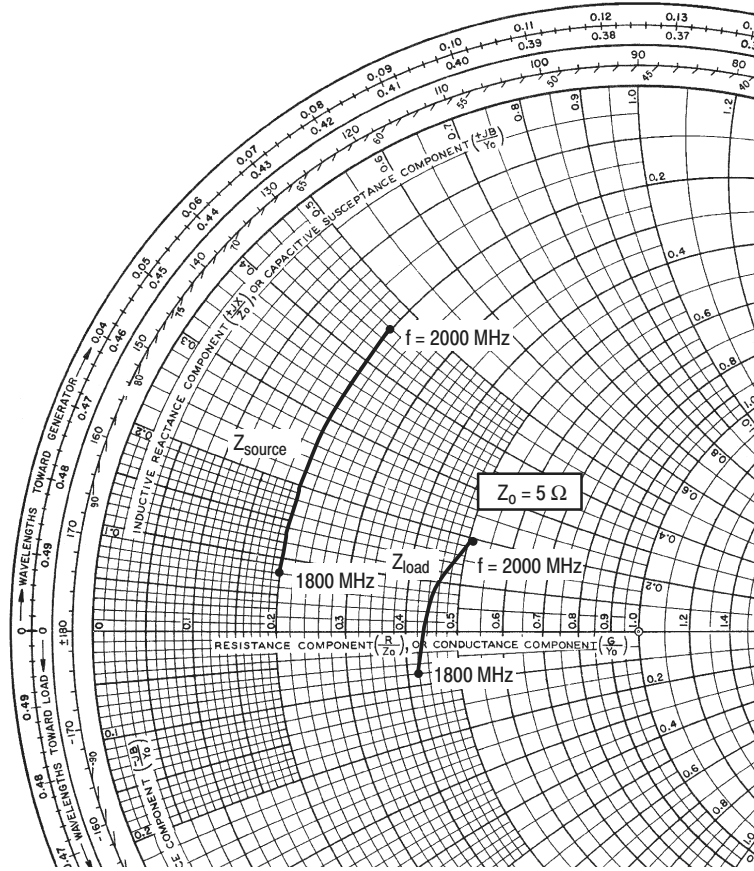

Figure 14. 1.92–2.0 GHz Broadband Circuit Performance



This graph displays calculated MTBF in hours \times ampere² drain current. Life tests at elevated temperature have correlated to better than $\pm 10\%$ of the theoretical prediction for metal failure. Divide MTBF factor by I_D^2 for MTBF in a particular application.

Figure 15. MTBF Factor versus Junction Temperature



$V_{CC} = 26 \text{ V}$, $I_{DQ} = 200 \text{ mA}$, $P_{out} = 15 \text{ W Avg.}$

f MHz	Z_{source} Ω	Z_{load} Ω
1800	$1.0 + j0.4$	$2.1 - j0.4$
1860	$1.0 + j0.8$	$2.2 + j0.2$
1900	$1.0 + j1.1$	$2.3 + j0.5$
1960	$1.0 + j1.4$	$2.5 + j0.9$
2000	$1.0 + j2.3$	$2.6 + j0.92$

Z_{source} = Test circuit impedance as measured from gate to ground.

Z_{load} = Test circuit impedance as measured from drain to ground.

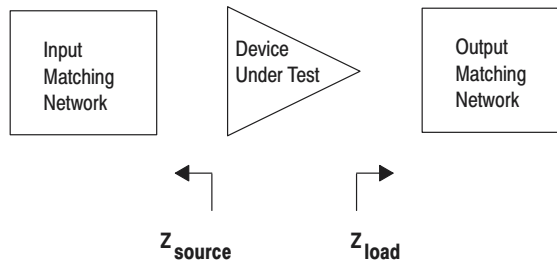
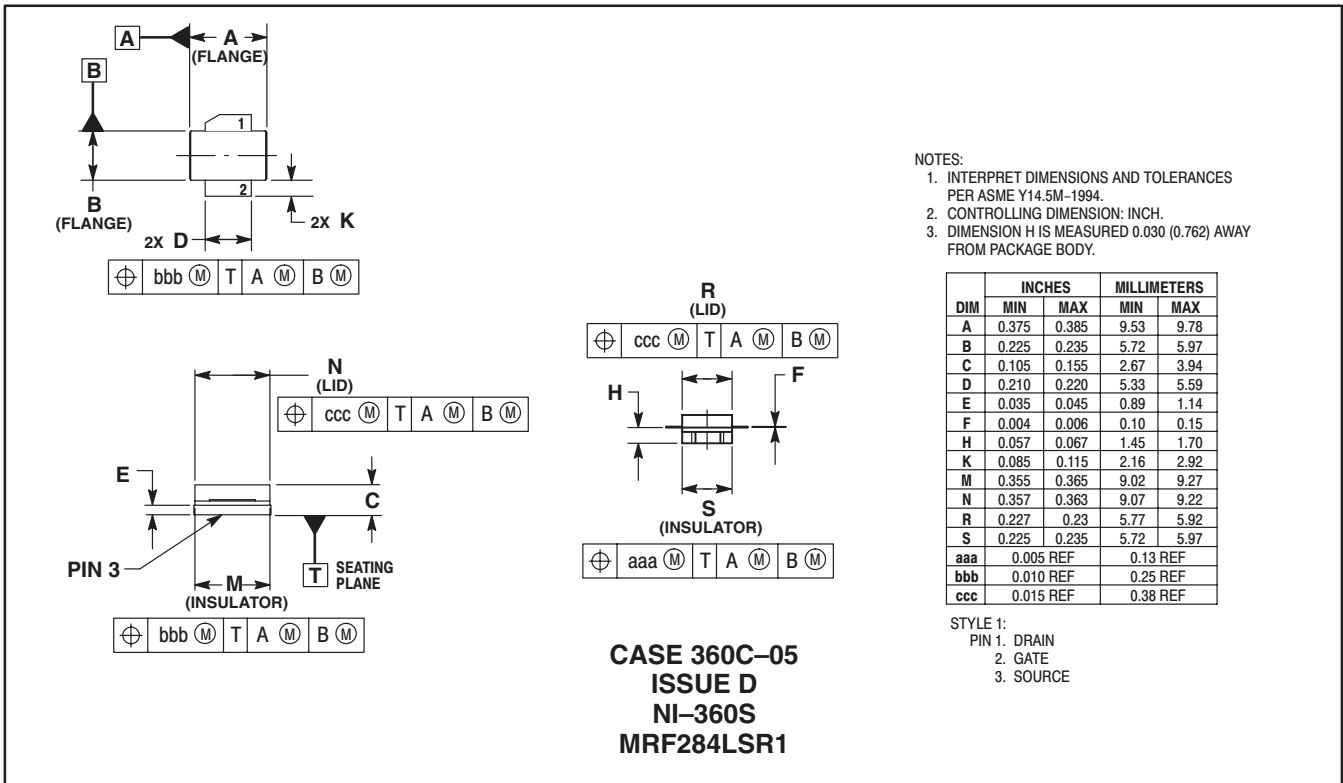
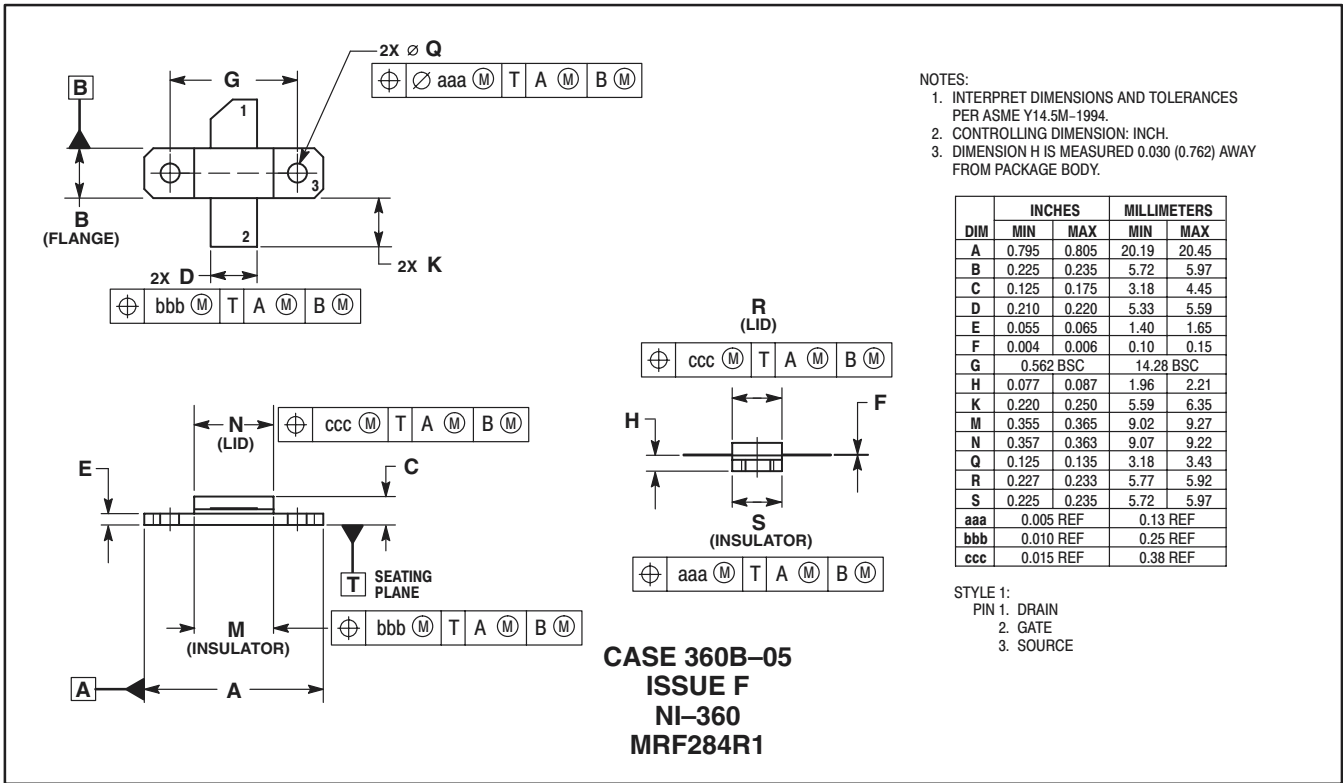

Figure 16. Series Equivalent Input and Output Impedance

NOTES

PACKAGE DIMENSIONS



Motorola reserves the right to make changes without further notice to any products herein. Motorola makes no warranty, representation, or guarantee regarding the suitability of its products for any particular purpose, nor does Motorola assume any liability arising out of the application or use of any product or circuit, and specifically disclaims any and all liability, including without limitation consequential or incidental damages. "Typical" parameters can and do vary in different applications and actual performance may vary over time. All operating parameters, including "Typicals", must be validated for each customer application by customer's technical experts. Motorola does not convey any license under its patent rights nor the rights of others. Motorola products are not designed, intended, or authorized for use as components in systems intended for surgical implant into the body, or other applications intended to support or sustain life, or for any other application in which the failure of the Motorola product could create a situation where personal injury or death may occur. Should Buyer purchase or use Motorola products for any such unintended or unauthorized application, Buyer shall indemnify and hold Motorola and its officers, employees, subsidiaries, affiliates, and distributors harmless against all claims, costs, damages, and expenses, and reasonable attorney fees arising out of, directly or indirectly, any claim of personal injury or death associated with such unintended or unauthorized use, even if such claim alleges that Motorola was negligent regarding the design or manufacture of the part. Motorola and the Stylized M Logo are registered trademarks of Motorola, Inc. Motorola, Inc. is an Equal Opportunity/Affirmative Action Employer.

Motorola and the Stylized M Logo are registered in the US Patent & Trademark Office. All other product or service names are the property of their respective owners.

© Motorola, Inc. 2002.

How to reach us:

USA/EUROPE/Locations Not Listed: Motorola Literature Distribution; P.O. Box 5405, Denver, Colorado 80217. 1-303-675-2140 or 1-800-441-2447

JAPAN: Motorola Japan Ltd.; SPS, Technical Information Center, 3-20-1, Minami-Azabu. Minato-ku, Tokyo 106-8573 Japan. 81-3-3440-3569

ASIA/PACIFIC: Motorola Semiconductors H.K. Ltd.; Silicon Harbour Centre, 2 Dai King Street, Tai Po Industrial Estate, Tai Po, N.T. Hong Kong. 852-26668334

Technical Information Center: 1-800-521-6274

HOME PAGE: <http://www.motorola.com/semiconductors>

